

Screen#  
 Art Name  
 Item  
 Outer  
 Inner  
 Handle  
 Lid  
 Date

**THERMO-SERV®**

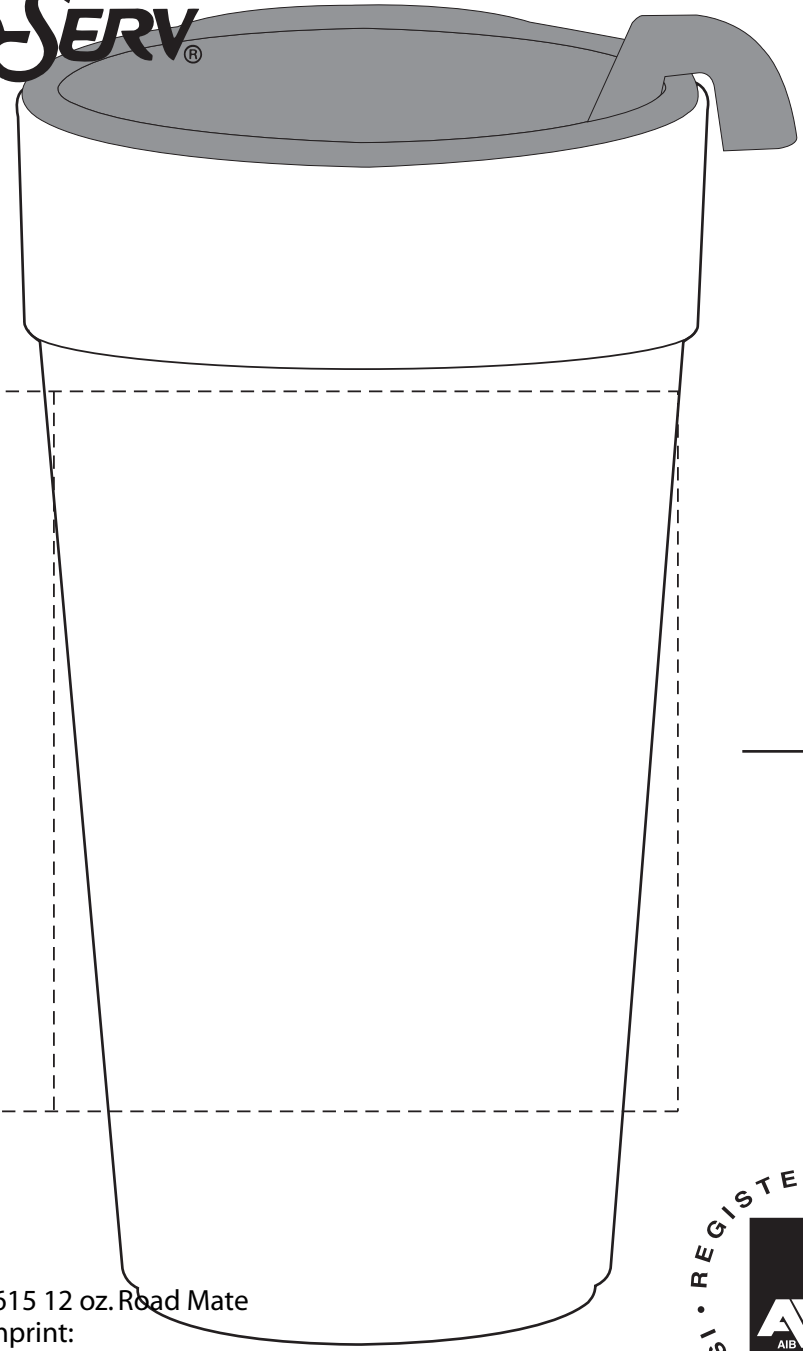

**MUST BE APPROVED PRIOR TO PRINTING!**

**PROOF! FOR POSITION ONLY • NOT AN EXACT COLOR MATCH**  
 Please refer to a Pantone® Color Guide for actual ink colors.

Please review your artwork carefully for misspelling, color selection and placement. Please make necessary corrections on this proof and return by mail or FAX. We assume no responsibility for errors or corrections that are not clearly marked on the attached proof. Please sign and date to indicate rejection or approval.

P.O.# \_\_\_\_\_  
 CUST: \_\_\_\_\_

Approved  
 Rejected

SIGNED \_\_\_\_\_ DATE \_\_\_\_\_  
 C.S.R. \_\_\_\_\_ ARTIST: **John**

#615 12 oz. Road Mate  
 Imprint:

